

From The People Who **Invented** Regenerative Air Sweeping!

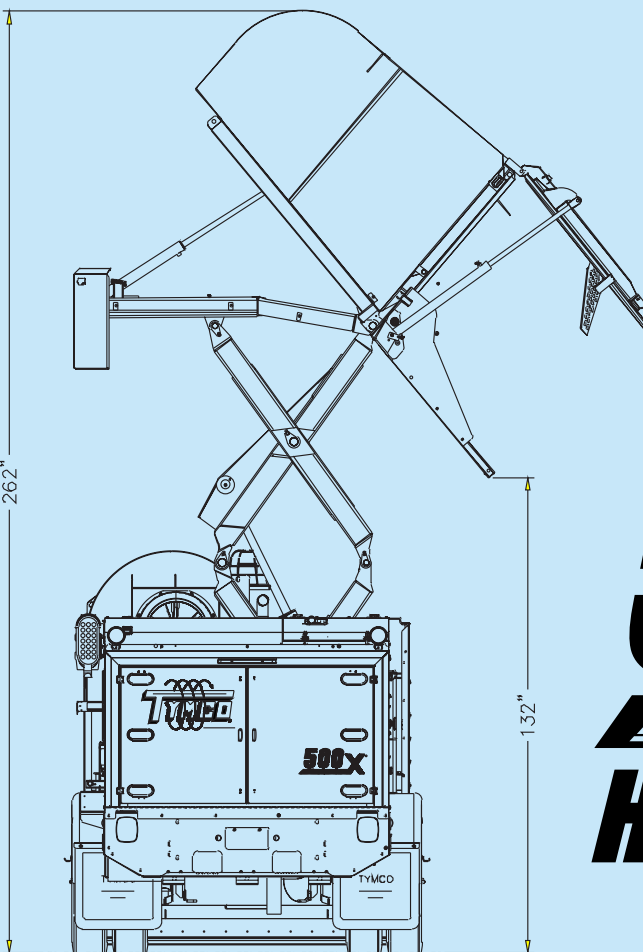

# 500x<sup>®</sup>

AIR SWEEPER

## High Side Dump

The TYMCO Model 500x<sup>®</sup> High Side Dump REGENERATIVE AIR Sweeper is the most innovative product of its kind on the market today. Developed to fulfill the requirements of municipalities, highway departments and contractors who have the need for high dump sweeper applications; the 500x<sup>®</sup> comes fully equipped with features unmatched in the industry. The Model 500x<sup>®</sup> features a variable dump height from 2 feet to 11 feet from the tip of the discharge chute to the ground with the hopper fully tilted, enabling the 500x<sup>®</sup> to dump into various size containers. The fast 68 second dump cycle means more time sweeping, less time dumping.

Sweeper photographs may contain optional equipment. Consult your dealer for more information.

## Superior Training

We want you to understand the Regenerative Air System and your TYMCO Sweeper completely, so you can get optimal performance from your equipment investment. That's why, for more than thirty years, we've offered two-day scheduled training schools at our facility in Waco, Texas. Managers, owners, operators and mechanics get hands-on training and answers to specific questions. Enrollment levels are kept low, so you and your team will get personal attention as well as the opportunity to learn from the experiences of other attendees through the interaction of the class.

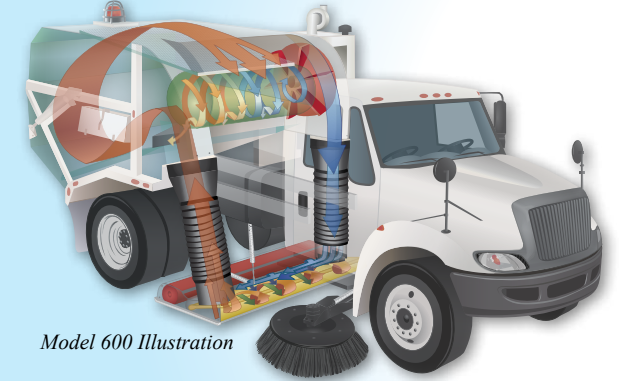

Model 600 Illustration

When your operators and mechanics are thoroughly trained and knowledgeable about the TYMCO Sweeper, you get better performance and a lower cost per operating hour.

- TYMCO offers full two-day schools
- Choose from over 30 schools scheduled per year
- Yearly class schedules and class agendas are available
- Learn through demonstrations on an operational sweeper
- Special schools arranged for large groups
- Register to attend on [tymco.com](http://tymco.com)

Specifically designed for training, our 3500 square foot, temperature controlled facility provides ample space for demonstrations on an operational sweeper and systems components. We also provide daily ground transportation from the hotel to our training facility, and lunch is on us.



### Convenient Dealer Service Centers

In over 50 U.S. locations and dozens of others worldwide, you receive on-the-spot parts and service from TYMCO's network of dealers.

This product is protected by numerous U.S. and Foreign Patents.

Specifications subject to change without notice.



**MODEL HSP<sup>®</sup>**  
High Speed Performance for Airport Runways



**MODEL 435<sup>®</sup>**  
Mid-Sized Street Sweeper



**MODEL 600<sup>®</sup> COMDEX<sup>®</sup>**  
Compact Design Extra Water



**MODEL 600<sup>®</sup> CNG**  
Compressed Natural Gas Powered

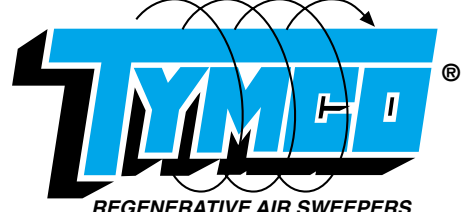

**MODEL DST-4<sup>®</sup>**  
Dustless Sweeping Technology



**MODEL DST-6<sup>®</sup>**  
Dustless Sweeping Technology



**MODEL 210<sup>®</sup>**  
Parking Lot Sweeper

**TYMCO REGENERATIVE AIR SWEEPERS are South Coast AQMD Rule 1186 PM<sub>10</sub> Certified**

Sweeper chassis models may change without notice. 0815 - 6M - 01SM © TYMCO, Inc. 2015



# Regenerative Air Sweeper<sup>®</sup>

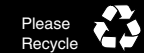



# BlueLogic® Control System

The BlueLogic® Control System is the TYMCO multiplex electronics platform that delivers reduced wiring, LED diagnostics among other advanced features.



In cab controls are center mounted and illuminated for ease of operation from either driving position. Switches integrate multi-color LEDs giving operators instant feedback on sweeper functions.



The high resolution color display delivers on-board diagnostics for the TYMCO BlueLogic® Control System and the auxiliary engine's ECU (Engine Control Unit). Service reminders for the auxiliary engine and hydraulic system fluids and filters are also included.

The TYMCO patented dual 43 inch vertical digger gutter brooms are both variable speed and tilting. The brooms are illuminated for night sweeping.

The Broom Assist Pick-up Head (BAH®) provides an on-demand broom for applications where a center broom may be desired. In-cab controls allow for broom assisted sweeping only when needed, reducing broom wear.



No Grease Fittings=Less Maintenance



The TYMCO exclusive Tilt-N-Seal® blower system utilizes an adjustable spring balance design which ensures long seal life between the hopper and blower housing. The hydraulically driven blower does not operate during the dump cycle and is accessible without having to remove the blower housing.

The dust control system features a 250 gallon capacity rustproof reservoir with a hydrant fill hose and low level indicators. Additionally, the dust control system does not operate when the blower is disengaged; thereby saving water.

The large 5.7 cubic yard hopper offers a variable dump height from 2 feet to 11 feet (24 inches to 132 inches) allowing dumping into various size and type containers.



The heavy duty hopper, screens and high capacity dust separator are constructed of non-magnetic stainless steel. The hopper is designed with integral openings for cleaning above the screens without the use of drop down screens or access panels. The large hopper door allows easy dumping and is hydraulically and mechanically locked for an air and watertight seal.

The hopper drain system allows for sweeping in wet weather.

The heavy duty scissor lift assembly has a 10,000 lb. lift capacity. All pivots on the lift are self-lubricating and never require greasing. Integral counterbalance holding valves ensure controlled lowering of the lift assembly and serve as redundant safety locks.



The powerful 115 HP diesel auxiliary engine is located at the rear of the sweeper, reducing cab noise and heat, while also allowing easy ground level access. Compressed Natural Gas (CNG) auxiliary engine also available.

Dual stabilizers automatically deploy before the dump cycle begins assuring unit stability throughout the dumping process.



Available in CNG

## TYMCO Regenerative Air Cleans Deeper™



The TYMCO Model 500x® has a large stainless steel discharge chute, which projects debris into the middle of the container without the need of a side shift. The chute is designed to float 45 degrees upward, preventing major damage should it come in contact with the debris container.



International® Conventional Cab Chassis



Freightliner® Conventional Cab Chassis

### Chassis Features

- Dual Steering with Tilt and Dual Instrumentation
- Excellent Visibility, Maneuverability and Accessibility
- Dual Adjustable High Back Air Suspension Seats
- Remote Controlled Heated Power Mirrors



Freightliner® Conventional Cab Chassis  
CNG (Compressed Natural Gas Powered)

Sweeper chassis models and options may change without notice. Specifications subject to change without notice. Consult factory.

Sweeper photographs may contain optional equipment. Consult your dealer for more information.